

MODEL DPI65500 DRIVER PACK SERIES



- Interfaces with CLCI 500 Series Computer Indexers
- Top Breakout Board brings out indexer functions to screw terminals
- 1 to 6.5 Amps per Phase
- Full and Halfstep Operation
- Motor Turn Off Provisions
- TTL/CMOS Compatible Inputs
- Compact and Rugged
- Single or Dual Axis Unit

GENERAL DESCRIPTION

The DPI Series Driver Packs are designed to interface directly with the CLCI500 Series Computer Indexers via a DB37 cable. The DPI contains one or two axes of bilevel drivers and a breakout board. The bilevel drivers are designed to operate 4-phase step motors providing significantly improved motor speed torque output. These drivers are rated at 6.5 Amps per phase. The purpose of the breakout board is to allow for easy connection of Inputs, Outputs, and Limit Switches to the indexer. These signals come out directly to the 12-pin and 20-pin terminal blocks on the DPI.

BILEVEL DRIVE

The basic function of a step motor driver is to control the motor winding currents. Motor performance is determined by the speed at which the driver can increase and decrease the winding currents. A rapid rise in winding current is achieved by applying a high voltage directly to a motor winding until a predetermined current level is reached. Then a low voltage is applied to maintain a suitable holding current level. When a motor winding is de-energized (turned off), a rapid decrease in winding current is achieved by routing the energy in the collapsing field back to the power supply through a high voltage path. The high voltage supply furnishes the energy necessary to maintain motor output torque at high step rates thus providing high mechanical power output. The low voltage supply provides much of the current needed at low step rates and all of the holding current.

The bilevel drive technique achieves outstanding motor performance without using dropping resistors. L/R drive technique uses dropping resistors to enhance the drive circuit time constant and limit phase currents. This results in only moderate motor performance. The cost of the resistors, packaging considerations, heat dissipation, and added power supply cost and bulk makes the use of the L/R technique altogether impractical for most applications.

Bilevel drivers do not use high frequency switching techniques as chopper drivers do. Consequently, they do not create the EMI, RFI, and motor heating problems that are associated with chopper drivers.

CLOCK AND DIRECTION CONTROL

The Computer Indexer creates the CLOCK and DIRECTION signals for the drivers and sends these signals along the 37 pin cable to the breakout board. These signals are internally connected from the breakout board to the drivers. No connections should be made to the CLOCK and DIRECTION inputs on the driver (13-pin) terminal blocks.

MODE SELECT

Terminal 8 on the driver (13-pin) terminal block is assigned as the excitation MODE SELECT input. The MODE SELECT input is used to select either half-step or full-step (dual phase excitation) motor operation. Half-step operation is generally preferred

because this mode provides better resolution, minimizes resonance effects, and reduces power consumption. In half-step the motor steps in increments of half the natural step angle, e.g. in 0.9 degree steps for a 1.8 degree step motor. Full-step operation is recommended only for applications that specifically require the mode, such as when retrofitting existing full-step systems.

MOTOR ON/OFF INPUT

The MOTOR ON/OFF input can be used to turn off all four motor phases (de-energize the motor) in applications where motor detent torque is sufficient to maintain the load position. This feature can be used to reduce the load on the power supply and the heat dissipation in the driver circuitry and motor. Terminal 9 on the driver (13-pin) terminal block is the MOTOR ON/OFF Input. By placing the jumpers on the breakout board (top board) in the appropriate positions, Indexer OUTPUTS may be connected to this input internally (see Table 2).

ADJUSTING THE KICK CURRENT

The kick current level is the desired phase current level that the high voltage provides each time a step is taken. The high voltage is turned on at the beginning of each step and turned off when the kick current level is reached. The kick current potentiometer should be set to the rated motor phase current (refer to the silkscreen on the side of the chassis for kick current level). This setting internally sets the kick current level



ANAHEIM AUTOMATION

910 East Orangefair Lane, Anaheim, CA 92801
e-mail: info@anaheimautomation.com

(714) 992-6990 fax: (714) 992-0471
website: www.anaheimautomation.com

forty percent over the motor's rated current. **WARNING:** The kick current level must be set before operating a motor.

MOTOR CONNECTIONS

Motor wires are connected to the driver pack through terminals 1, 2, 3, 11, 12, and 13 on the 13-pin terminal blocks. A typical hookup diagram is shown in Figure 3. Electrical connections to control inputs should be kept physically separated from the motor cables.

JUMPERS

The jumpers on the driver boards (vertically mounted side boards) should NOT be moved from the original position as shipped from the factory. In the event that these jumpers are moved, replace these jumpers to the lower positions.

Two of the jumpers on the breakout board (top board) are used to connect the **OUTPUTS** of the CLCI500 to the Motor **ON/OFF** input of the drivers. These jumpers are set to connect the indexer Outputs to the driver ON/OFF inputs when shipped from the factory. The other two jumpers are for use with future driver boards. See Table 2 and Figure 1 for details on jumpers.

DRIVER SPECIFICATIONS:
(13-pin terminal block)

Control Inputs:

Logic "0": 0 to 0.8 Vdc.
Logic "1": 3.5 to 5 Vdc.

Mode Select: (Terminal 8)

Logic "1" (open) - Halfstep
Logic "0" - Fullstep

Motor ON/OFF: (Terminal 9)

Logic "1" (open) - motor energized
Logic "0" - motor de-energized

Output Current Rating:

(Terminal 1, 2, 3, 11, 12 & 13)
6.5 Amperes per phase over the operating voltage and temperature range. Motor phase current ratings of 1.0 Amperes minimum are required to meet the minimum kick level.

Power Requirement:

105 VAC to 125 VAC

Operating Temperature:

0 to 60 degrees C.

Please refer to the CLCI500 User's Manual for specifications on Indexer functions (INPUTS, OUTPUTS, LIMITS, etc.)

DPI65501	Single Axis for use with CLCI500
DPI65502	Dual Axis for use with CLCI500

TABLE 1: ORDERING INFORMATION.

DPI65500 Series (for CLCI500) Jumpers	
JP1	for future use.
JP2	for future use.
JP3	1 to 2: OUT2 connected to ON/OFF Axis A 2 TO 3: Not Connected
JP4	1 TO 2: OUT5 connected ON/OFF Axis B 2 to 3: Not Connected

TABLE 2: Jumper Settings.

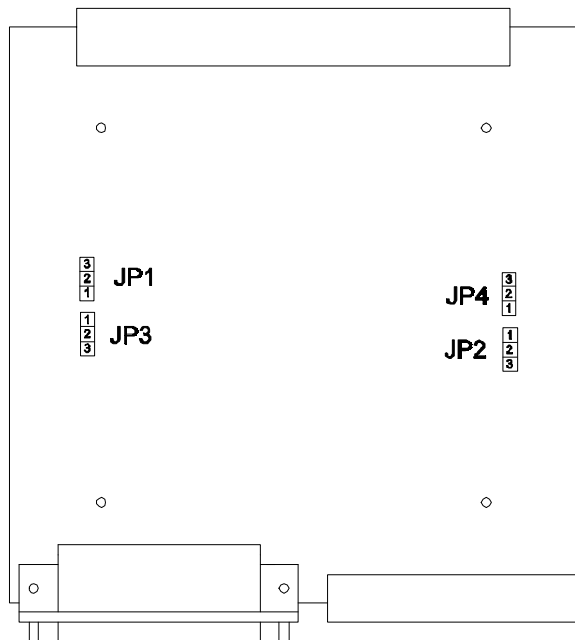

FIGURE 1: Jumper Locations on Breakout Board.

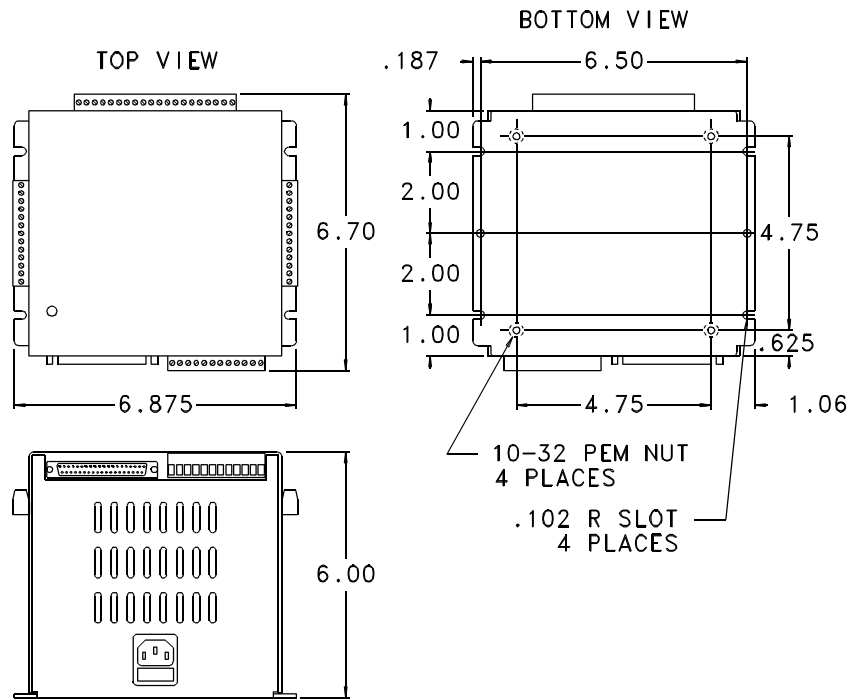

FIGURE 2: Dimensions.

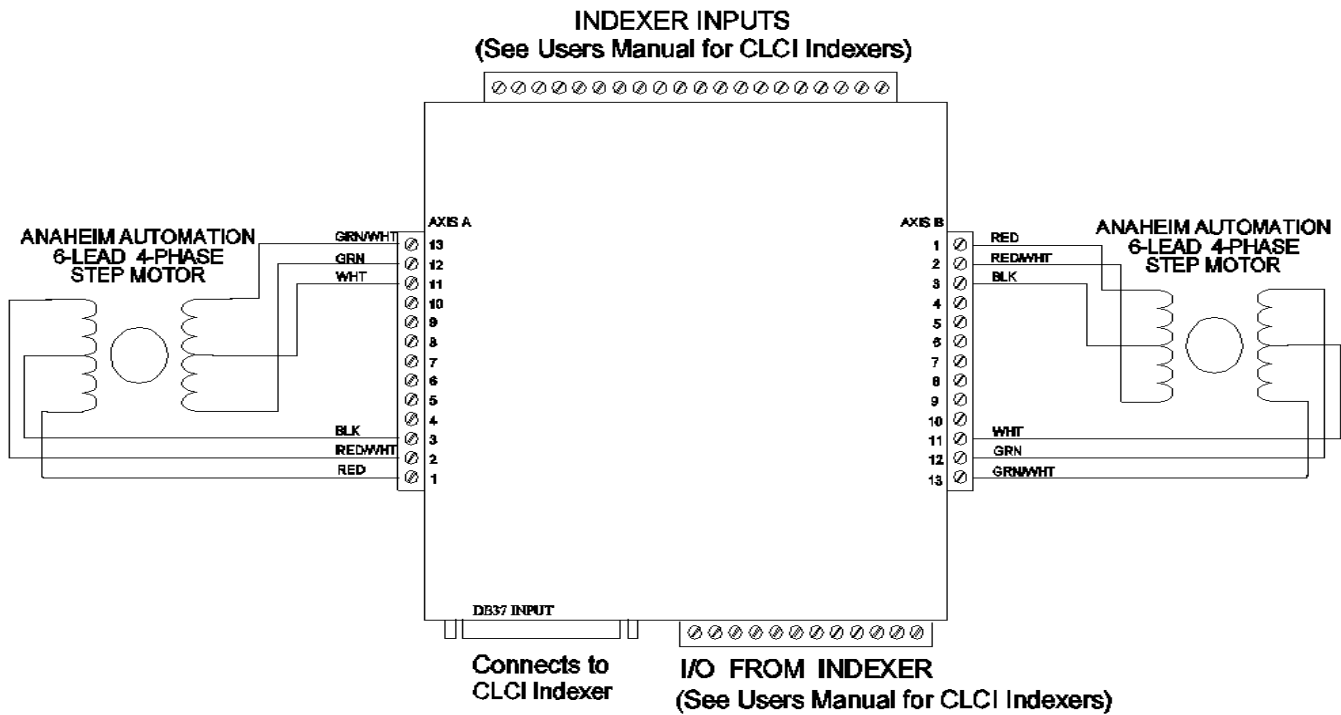
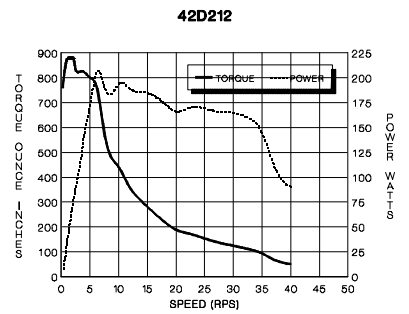
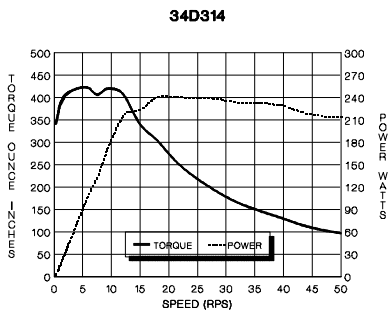
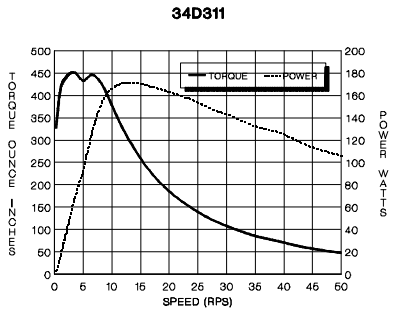
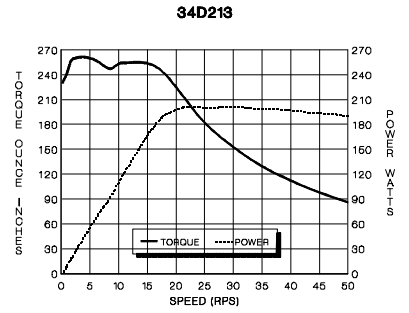
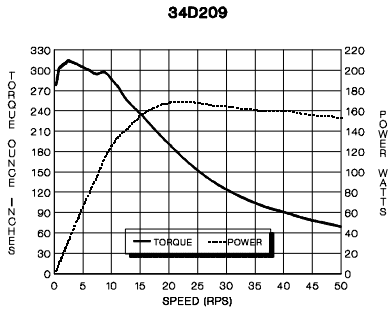
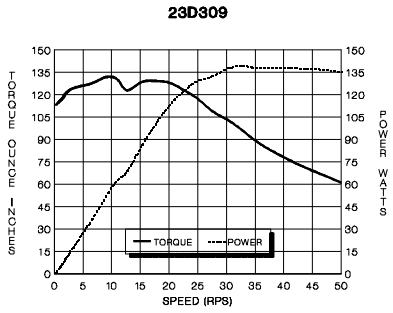
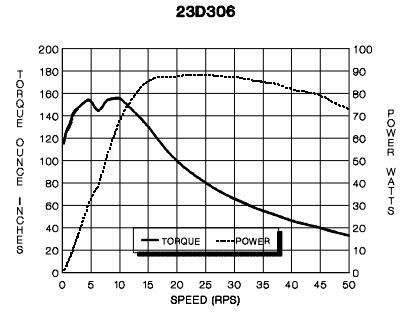
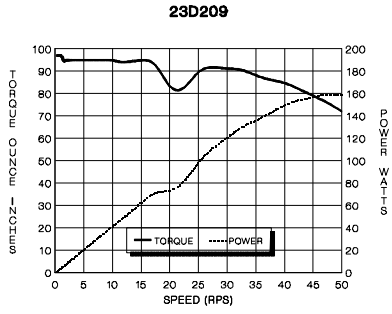
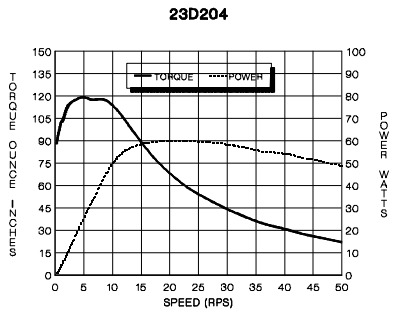

FIGURE 3: Motor Hookup Diagram.



TERMINAL	DESCRIPTION
1	A:HARD-
2	A:HARD+
3	A:SOFT-
4	A:SOFT+
5	A:HOME-
6	A:HOME+
7	A:JOG+
8	A:JOG-
9	A:FASTJOG
10	B:HARD-
11	B:HARD+
12	B:SOFT-
13	B:SOFT+
14	B:HOME-
15	B:HOME+
16	B:JOG+
17	B:JOG-
18	B:FASTJOG
19	+5VDC OUT
20	0VDC

TABLE 3: TB1 Description

TERMINAL	DESCRIPTION
1	IN1
2	IN2
3	IN3
4	OUT1
5	OUT2
6	OUT3
7	IN4
8	IN5
9	IN6
10	OUT4
11	OUT5
12	OUT6

TABLE 4: TB2 Description

TERMINAL	DESCRIPTION
1	PHASE 1
2	PHASE 3
3	COMMON 1,3
4	VLV
5	DIRECTION
6	CLOCK
7	0VDC
8	HS/FS
9	ON/OFF
10	VHV
11	COMMON 2,4
12	PHASE 2
13	PHASE 4

TABLE 5: Driver Terminals